

Monnit

Wireless Resistance Sensor

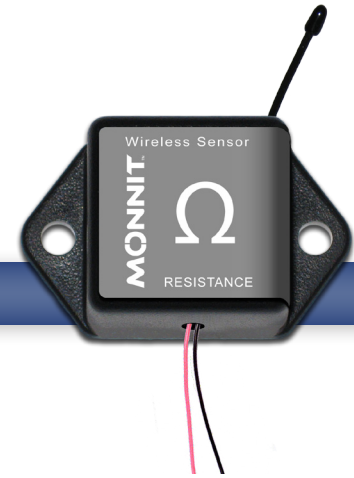

Technical Overview

General Description

The Monnit Wireless Resistance Sensor outputs the resistance across a load. It can be connected to any kind of variable resistance device, such as a transducer or sensor that outputs voltage. If the device to be measured is passive, the user must supply their own excitation voltage to the device. To reduce error, a variable resistor configuration is implemented on the ADC to cover specific resistance ranges.

Features

- Measures up to 145 KOhms.
- Accurate to $\pm 1.5\%$ (FS) with user calibration.
- Interfaces with any variable resistance device.
- Free iMonnit basic online wireless sensor monitoring and notification system to configure sensors, view data and set alerts via SMS text and email.

Principle of Operation

The Monnit Wireless Resistance Sensor outputs the resistance across a load. It is programmed to sleep for a user-given time interval (heartbeat) and then wakeup, send power to the load resistor, wait for it to stabilize, and convert the analog data, mathematically compute the resistance and transmit the data to the gateway, where it is then logged into a cloud service. The user can configure defined thresholds and have the system alert on threshold breaches. Data is recorded in Ohms.

Power Options

Sensors are powered by a replaceable 3.0 V coin cell battery. Optional AA battery powered sensors are available. The AA version of these sensors are larger in size (3" [L] x 2.1" [W] x 1.2" [H]) and include two long-life AA batteries.

It is recommended that unless you are using the AA battery solution, you set heartbeat to no faster than one hour to preserve battery life. Battery power cannot be supplied off the device to power the transducer or sensor.

Monnit Sensors Core Specifications

- Power: Replaceable 3.0 V coin cell battery
- Communication: RF 900, 920, 868 and 433 MHz
- Dimensions: 1.775" x 1.040" x 0.785"
- Antenna: 4" wire antenna
- Operating Temperature: -7° to 60°C (20° to 140°F)
- Device Range: 250 - 300 ft. non-line-of-sight*
- Battery Life: At 1 hour heartbeat setting, coin cell battery will last ~ 1-2 years.**

* Actual range may vary depending on environment.
** Battery life is determined by sensor reporting frequency and other variables.

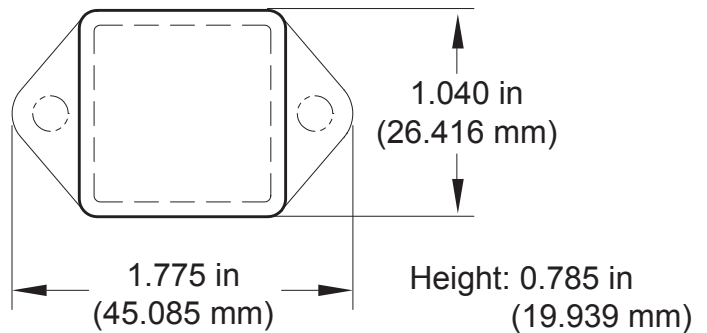

Example Applications

- Resistance Monitoring
- Battery Monitoring
- Transducer Interfacing

The Leader in Low Cost Wireless Sensors

Technical Specifications	
Supply Voltage	2.0 - 3.6 VDC *
Current Consumption	0.7 μ A (sleep mode) 2 mA (radio idle/off mode) 2 mA (measurement mode) 25 mA (radio RX mode) 35 mA (radio TX mode)
Operating Temperature Range (Board Circuitry and Coin Cell)	-7°C to +60°C (20°F to +140°F)**
Optimal Battery Temperature Range (Coin Cell)	+10°C to +50°C (+50°F to +122°F)
Resistive Range (in Ohms)	0 – 145000***
Specific Resistive Ranges (in Ohms)	0 – 530, 530 – 3500, 3500 – 27200, 27200 - 145000
Resolution (in Ohms)	2047 Unique Values Per Specific Range (11 bit): ~.25, ~1.71, ~13.3, ~70.8.
Accuracy	+/- 3% FS of Specific Range
User Calibrated Accuracy	+/- 1.5% FS of Specific Range****
Lead Wire Length	1 ft. (12 in.)
Certifications	 900 MHz product; FCC ID: ZTL- RFSC1 and IC: 9794A-RFSC1. 920 MHz product; ARIB STD-T108 R210-103733. 868 and 433 MHz product tested and found to comply with: CISPR 22:2008-09 / EN 55022:2010 - Class B and ETSI EN 300 220-2 V2.4.1 (2012-05).

* Hardware can not withstand negative voltage. Please take care when connecting a power device.

** At temperatures above 100°C, it is possible for the board circuitry to lose programmed memory.

*** The sensor is capable of measuring above 145000 Ohms but may not meet the specified accuracy above this value.

**** For a valid calibration, the resistance under measurement must be maintained in circuit for 1 data transmission before calibration and 1 data transmission after calibration. Calibration is only applied to the specific resistive range, for best results calibrate at a resistance between 10% and 90% of the specific range. In general, calibrating between the 50% and 90% points of the specific range will yield better calibration results for the entire range.

Caution/Notice:

This product is designed for application in an ordinary environment (normal room temperature, humidity and atmospheric pressure). Do not use this sensor under the following conditions as these factors can deteriorate the product characteristics and cause failures and burn-out.

- Corrosive gas or deoxidizing gas - chlorine gas, hydrogen sulfide gas, ammonia gas, sulfuric acid gas, nitric oxides gas, etc.).
- Volatile or flammable gas.
- Dusty conditions.
- Under low or high pressure.
- Wet or excessively humid locations.
- Places with salt water, oils chemical liquids or organic solvents.
- Where there are excessively strong vibrations.
- Other places where similar hazardous conditions exist.

Use this product within the specified temperature range. Higher temperature may cause deterioration of the characteristics or the material quality of this product.

For more information about our products or to place an order, please contact our sales department at 801-561-5555.

Visit us on the web at www.monnit.com.

MONNIT[™]

Monnit Corporation
7304 South Cottonwood
Suite #204
Midvale, Utah 84047
801-561-5555
www.monnit.com