

Monnit Wireless Range Extender Product Use Guide



Information to Users

This equipment has been tested and found to comply with the limits for a Class B digital devices, pursuant to Part 15 of the FCC Rules. These limits are designed to provide reasonable protection against harmful interference in a residential installation. This equipment generates, uses, and can radiate radio frequency energy and, if not installed and used in accordance with the instruction manual, may cause harmful interference to radio communications. However, there is no guarantee that interference will not occur in a particular installation. If this equipment does cause harmful interference to radio or television reception, which can be determined by turning the equipment off and on, the user is encouraged to try to correct the interference by one of more of the following measures:

- Reorient or relocate the receiving antenna
- Increase the separation between the equipment and receiver
- Connect the equipment into an outlet on a circuit different from that to which the receiver is connected.
- Consult the dealer or an experienced radio/TV technician for help.

WARNING: Changes or modifications not expressly approved by Monnit could void the user's authority to operate the equipment.

RF EXPOSURE WARNING: To satisfy FCC RF exposure requirements for mobile transmitting devices, a separation distance of 20 cm or more should be maintained between the antenna of this device and persons during device operation. To ensure compliance, operations at closer than this distance are not recommended. The antenna used for this transmitter must not be co-located in conjunction with any other antenna or transmitter.

The primary function of the Range Extender is to act as a range extender in places where wireless sensors are out of range of a Monnit wireless gateway.

Inside the Box

You should find the following items in the box:

- Monnit™ Wireless Range Extender
- Antenna

Monnit Wireless Range Extender Principle of Operation

On power up, the range extender will locate a gateway that has the “best” wireless signal available. The device then auto-configures itself to communicate and link with this gateway. After linking with the parent gateway, it then establishes itself as a sub-network with it’s own dedicated channel to the gateway, relieving congestion from multi-sensor networks.

Delays Associated with Using Wireless Range Extenders

Data coming from a sensor is delivered to a range extender and forwarded onto the gateway. In all implementations where network traffic is kept below 6 messages per minute, the worst-case lag through a range extender to the network is 20 seconds. If more than 6 messages are generated by wireless sensors talking through a range extender, it is possible to experience data lag beyond 20 seconds.

Monnit Wireless Range Extender Features

- Extends the coverage area of your wireless sensor network.
- Supports 6 messages / minute.
- Built in memory can queue up to 30,000 messages for delivery to the gateway.
- AC powered, so no batteries needed.

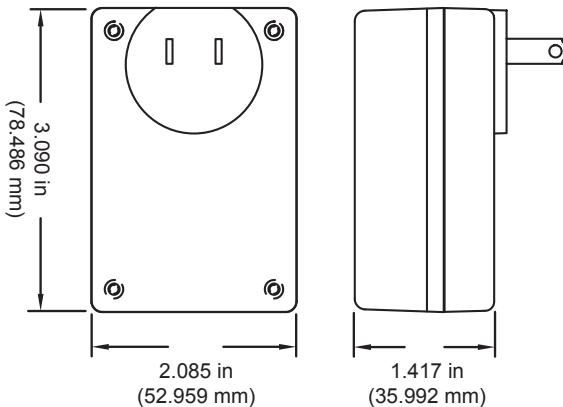

*** Important** - If the range extender is unplugged or loses power, all sensor messages stored on the device will be lost!

Using the Wireless Range Extender

1. Adding a Wireless Range Extender to a Sensor Network

Monnit wireless range extenders can be added to any Monnit sensor network through the iMonnit online sensor monitoring software.

Steps to add Wireless Range Extenders to your Sensor Network.

- Choose “Manage” from the main navigation.
- Select the network you would like to add the range extenders to.
- Find the bottom of the section “Sensor List / Assign Sensor”.
- Enter the ID and Security Code from the back label of the range extender.
- Press the “Assign Sensor” button.
- Repeat this process to add more range extenders to the network.

Sensor List / Assign Sensor

Sensor Name	Sensor ID	Sensor Type
-------------	-----------	-------------

Assign New Sensor

Sensor ID

Security Code

Contains FCC ID: ZTL-RFSC1
and IC: 9794A-RFSC1

This device complies with Part 15 of the FCC Rules. Operation is subject to the following two conditions:
(1) this device may not cause harmful interference and
(2) this device must accept any interference received, including interference that may cause undesired operation.

www.monnit.com
PN: SCM-91A-0RP
© 2012 Monnit Corp.

ID: #XXXXXX
Code: XXXXXX

Once the range extender has been added to your network, you will need to update and push the sensor device list to your range extender so it knows what sensors to allow communication with. For a USB gateway, go to the Monnit gateway application/service and click “Download Sensor Updates”. For an Ethernet gateway, power cycle the device by unplugging it, waiting 10 seconds then plugging it back in. For a Cellular gateway, use the power button to turn it off, wait 10 seconds then turn it back on.

After resetting the gateway, plug the range extender into an AC wall outlet. The range extender will have a green light when it has found the network. If the light is steady red, check the network, unplug it and try again.

2. Wireless Range Extender Light Indicator

Flashing Red/Green – the range extender is looking for a gateway to join.
Solid Red - no network found.
Solid Green – range extender has joined a network.
Flashing Green – sensor data traffic is intercepted and relayed.

3. Wireless Range Extender Data



Date	Signal	Battery	Sensor Reading
7/16/2012 4:17 PM	39	100	DCnt:7 Rxm:7 Fls:0 Qu:1 Chan:24
7/16/2012 4:16 PM	39	100	DCnt:7 Rxm:7 Fls:0 Qu:1 Chan:24
7/16/2012 4:15 PM	36	100	DCnt:7 Rxm:7 Fls:0 Qu:1 Chan:24

The range extender reports on five data parameters. The first, DCnt, is for *Device Count* and indicates how many sensors the range extender is able to recognize as being in the network. This count may add up to all sensors in the network, or it may only indicate those sensors that are talking through it, depending on how the range extender was able to provision its network.

Rxm stands for *Received Messages*. In the above example, there were 7 messages that were picked up by the range extender and sent through to the network.

Fls stands for *Failures*. In the event that network traffic overwhelms the range extender, the number of messages that were attempted to be delivered but failed are recorded.

Qu stands for *Queue*. If the range extender is overwhelmed with message traffic, it will report on the number of messages it has queued, but has not delivered up to the network. As the range extender recovers, this number will dwindle until it gets back to 1 as messages are successfully delivered up to the network.

Chan stands for *Channel*. In the process of forming a sub network, the range extender picks a different channel to communicate to the sensors on, to help avoid accumulating too much traffic on the same network.

4. Wireless Range Extender - Determining Connections

When using sensors with a wireless range extender, the sensors will automatically connect to the device with the strongest signal. The range extender should be placed between the sensor and the gateway.

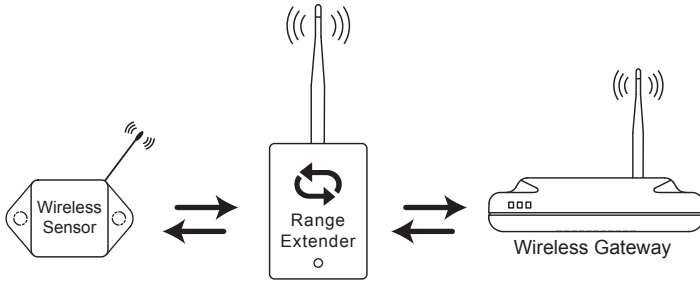

If the sensor detects a stronger signal from the range extender, it will automatically connect to the range extender.

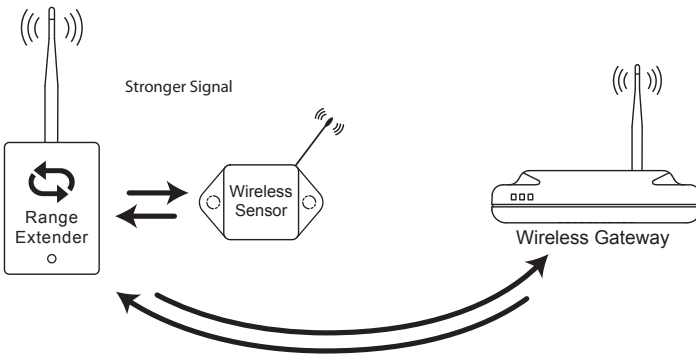

If the sensor detects a stronger signal from the gateway, it will automatically connect to the gateway and ignore the range extender.

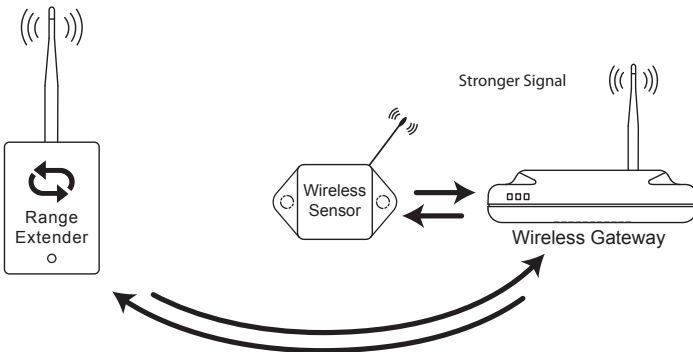

Monnit Wireless Range Extender Specifications

Power

Standard Operating Range	100-240 VAC
Max Operating Range	90-264 VAC
Input Frequency	50/60Hz +/- 3Hz
Max Power Consumption	1.0W

Wireless Operation

Maximum Wireless Devices Per Gateway	Up to 100 Total Wireless Devices Per Gateway
Maximum Sensors Per Range Extender	Up to 99 Wireless Devices (Range extenders count as wireless devices)
Message Storage / Memory	30,000 Messages
Recommended Network Communications	Up to 6 Messages Per Minute
Range Extender Communication Delay	Up to 30 Seconds (At number of recommended network communications)

Mechanical

LEDs	Single LED H/W Status / Activity - Flashing Red/Green (looking for a gateway to join) - Solid Red (no network found) - Solid Green (has joined a network) - Flashing Green (sensor data is intercepted and relayed)
Enclosure	ABS Plastic UL94V-0 Flame Rating
Dimensions	3.09 x 2.085 x 1.417 in. (78.486 x 52.959 x 35.992 mm)
Weight	4.5 ounces

Environmental

Operating Temperature	-40° to +85° C (-40° to +185° F)
FCC Approval:	ZTL- RFSC1

Monnit Wireless Range Extender FAQs

Will the range extender work with my current iMonnit Gateway and Monnit Express software?

It is advised to upgrade your Monnit Gateway and Monnit Express software to the latest version to help avoid issues while setting up and using your wireless sensors through a range extender. To update your software, please visit <http://www.monnit.com/support>.

How can I tell if I need a range extender?

Use a Monnit Button Sensor to assess the expected range of your environment. If the button sensor struggles to communicate with the gateway by flashing red, even occasionally, it is likely that any other sensor placed in the same location will struggle. You can also view the history of an operating sensor to see if you are getting good signal strength. If the signal strength is less than 50, or your button sensor is flashing red, even just occasionally, placing a range extender in between is advised.

Is the repeater compatible with my existing network?

If your existing network version begins with 2.x.x.x, the range extender is compatible. Any previous versions, 1.2.xxx, are not compatible.

What is the increase in range?

The range essentially doubles when a range extender is placed on the network. Depending on the environment, the range extender could increase the range of a sensor by up to 1600 ft. Multiple range extenders can be chained together to allow for even further range. (Note that in multiple range extender networks, for every relay point the number of messages doubles.)

Does the range extender lose data if it is not able to deliver immediately?

No, as long as the range extender has not lost communication with the network. If the range extender still has a link to the network, but has been unable to deliver a message because of network traffic or due to failures, it has the ability to store all data messages coming in. They will be delivered one after another as soon as the communication link is clear again.

For additional information or more detailed instructions on how to use your Monnit Wireless Sensors or sensor monitoring software, please visit us on the web at <http://www.monnit.com/support/>.



Monnit Corporation
7304 South Cottonwood
Suite #204
Midvale, Utah 84047
801-561-5555
www.monnit.com