



TECHNICAL SUBMITTAL DATA SHEET

Washing Machine Leak Detection & Automatic Water Shut-Off Outlet Box System

Job Name: _____	Job Location: _____
Engineer: _____	Engineer Approval: _____
Contractor: _____	Contractor Approval: _____
Contractor P.O.: _____	Representative: _____

MODEL RS-090-E

TYPICAL INSTALLATIONS INCLUDE:

- Single-family homes
- Condos
- Commercial apartment buildings
- Assisted living facilities

HIGHLY RECOMMENDED FOR:

- Applications where washing machine is located above the ground floor, where water from a leak will easily spread to lower floors
- Any washer hook-up that lacks a manual shut-off valve
- Facilities with a history of insurance claims for water damage
- Structures with high-end amenities

FEATURES:

- Plugs into a standard 120V AC outlet
- Water sensor with 8' lead wire
- Outlet box with (4) mounting straps and trim plate
- Integrated water hammer arrestors for hot and cold water lines
- Easy reset button; system is reusable
- Plugs into a standard 120V AC outlet
- Leak LED and audible alarm (86 dB)
- Factory pre-wired
- Insurance discount may be available upon installation

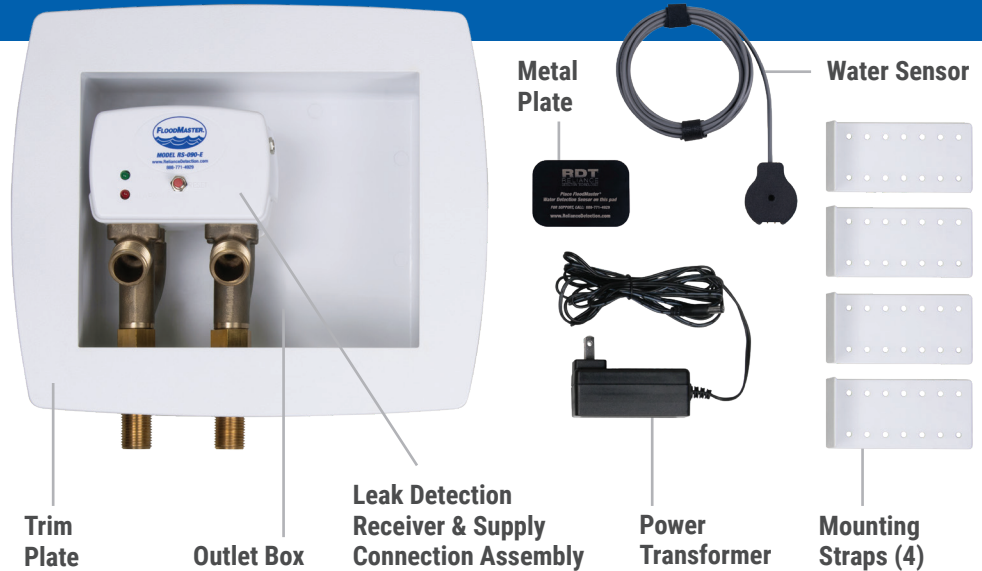

APPLICATION CONSIDERATIONS:

Did you know – Water from a burst washing machine hose can produce approx. 6 gallons of water a minute. That’s 650 gallons (2.5 tons!) of water in an hour.

The RS-090-E is suitable for installation on new construction, facility upgrades, tenant build-outs and retrofit projects. Care should be taken to ensure necessary rough opening space for outlet box (7.75" X 9" X 3.75"), along with hot and cold feed line positioning/spacing (2.52" on center). Also requires 120V AC power outlet within 6' of the leak detection receiver.

INSTALLATION OVERVIEW:

The system features an outlet box with built-in leak detection receiver for simultaneous hot and cold water automatic shut-off when a leak is detected. The kit also includes pre-installed water hammer arrestors on both the hot and cold water lines. The leak detection receiver is powered by a standard 120V AC wall outlet. Outlet box is secured to studs using supplied mounting straps. Water supply lines and appliance hoses connect at the appropriate points to the leak detection receiver, and the mechanical water shut-off device resides in between. Place leak detection water sensor on the floor next to or under the washer and plug the unit into the wall outlet. Finish installation by mounting supplied trim plate and securing drain hose in the provided 2-3/8" ID opening.

Emergency manual operation of the water shut-off valves is accomplished by disconnecting power to the unit. In the event of a power failure, the valves will fail closed (water off).

RDT recommends that installations be completed by a licensed plumber to ensure that all local codes requirements are followed.



RS-090-E TECHNICAL SUBMITTAL DATA SHEET

ORDERING INFORMATION:

Valve Size	P/N	UPC
Dual-port 1/2"	RS-090-E	811475030160

OPERATING SPECIFICATIONS:

Fittings

Supply Lines.... 1/2"-14 straight pipe thread
 Feed Lines 3/4"-11.5 GHT
 Max. Water Temp. 120°F
 Max. Water Pressure..... Tested to 80 PSI

Receiver Box / Actuator

Transformer 120V AC
 Voltage 30V AC
 Working Temp. 0° to 100°F
 Audible Alarm 86 dB

Water Hammer Arrestors

Hot & Cold Lines..... To ASSE 1010 requirements

MATERIALS:

Fittings

Body Brass
 End Connection Brass
 Complies with ASME A112.18/CSA B125.1-2012; NSF 372.

Leak Detection Receiver & Water Sensor

Body High-performance engineered polymer

Outlet Box & Mounting Material

Body Fire-rated PVC
 Meets UL94 Standard for Safety of Flammability of Plastic Materials for Parts in Devices and Appliances (materials only).

CABLE LENGTHS:

Power Cord 7'
 Sensor Cable..... 8'

OTHER APPROVALS:

MA Board of Registration of Plumbers Approval – Code # P1-1118-206.

DIMENSIONS & WEIGHTS:

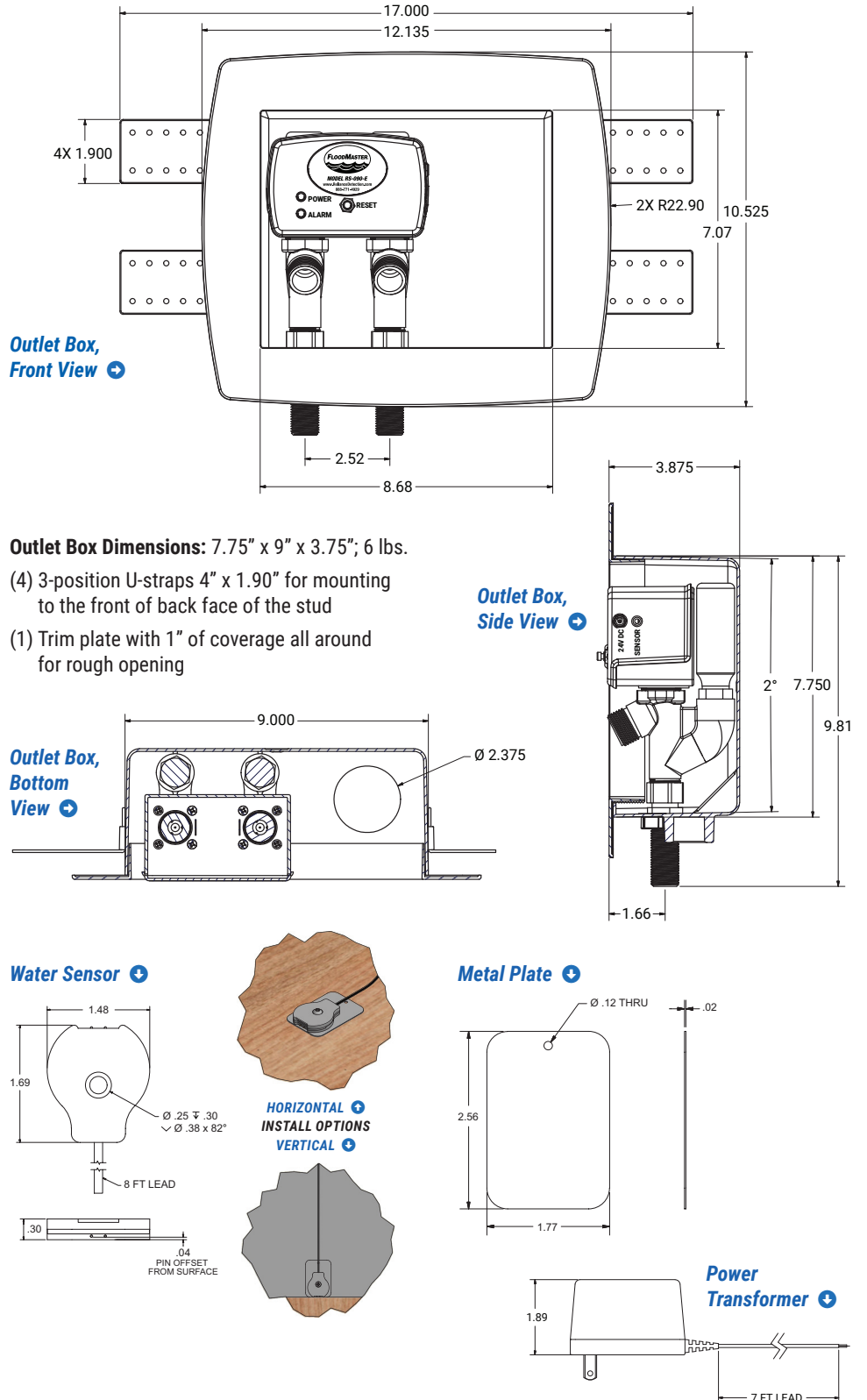

RDТ recommends that installations be completed by a licensed plumber to ensure that all local code requirements are followed.

Warning: For use with water only. Do not install on gas line. For indoor use only.
 This system requires a 120V AC wall outlet within 6 feet of the system.



Reliance Detection Technologies, LLC
 27 Business Park Drive
 Branford, CT 06405

203-488-2684 or 888-771-4929
 info@RelianceDetection.com
www.Reliandetection.com